

SERVICE & PARTS MANUAL – ELECTRIC STACKER

MODELS	ST-700-1500-E	ST-700-1500-E-ADJ
	ST-700-2100-E	ST-700-2100-E-ADJ
	ST-1000-1500-E	ST-1000-1500-E-ADJ
	ST-1000-2100-E	ST-1000-2100-E-ADJ

IMPORTANT NOTICE

PLEASE PASS THIS LEAFLET TO YOUR SAFETY OFFICER BEFORE USE AND KEEP IT IN A SAFE PLACE.

READ THOROUGHLY BEFORE USE AND FAMILIARISE YOURSELF WITH THE TRUCK AFTER READING THESE INSTRUCTIONS.

TEST CERTIFICATES SHOULD BE PASSED TO THOSE RESPONSIBLE FOR YOUR REGISTER OF LIFTING EQUIPMENT AND BE RETAINED FOR SCRUTINY BY A FACTORY INSPECTOR, INSURANCE COMPANY ETC.

NO LIFTING GEAR SHOULD BE PUT INTO USE WITHOUT A VALID TEST CERTIFICATE, NOR USED BY UNTRAINED STAFF WHO ARE NOT FULLY AWARE OF THE INSTRUCTIONS FOR SAFE USE. ALWAYS WEAR SAFETY SHOES WHEN WORKING WITH THIS PRODUCT. THE USER SHOULD REFER TO EN 1005-3.

TECHNICAL DETAILS

	ST-700-1500-E	ST-700-1500-E-ADJ	ST-700-2100-E	ST-700-1500-E-ADJ
BUILT TO	BS EN 1757-1: 2001 & BS EN 60204-1:1998			
MAX CAP	700 kg	700 kg	700 kg	700 kg
LOAD CENTRE	500 mm	500 mm	500 mm	500 mm
FORK LENGTH	1140 mm	1000 mm	1140 mm	1000 mm
MAX LIFT HEIGHT	1500 mm	1500 mm	1500 mm	1500 mm
WEIGHT	179 kg	213 kg	232 kg	272 kg

	ST-1000-1500-M	ST-1000-1500-M-ADJ	ST-1000-2100-M	ST-1000-1500-M-ADJ
BUILT TO	BS EN 1757-1: 2001 & BS EN 60204-1:1998			
MAX CAP	1000 kg	1000 kg	1000 kg	1000 kg
LOAD CENTRE	500 mm	500 mm	500 mm	500 mm
FORK LENGTH	1140 mm	1000 mm	1140 mm	1000 mm
MAX LIFT HEIGHT	1500 mm	1500 mm	1500 mm	1500 mm
WEIGHT	330 kg	360 kg	360 kg	390 kg

HANDLING & OPERATION

If delivered on a vehicle it should be lifted by crane, or if lifted by forklift secure to carriage. Check that it is secure before removing from a vehicle. This stacker was designed only to be used on flat, smooth firm ground.

UNFORESEEN USE

- **DO NOT** use with the battery connected
- **DO NOT** use with the battery cover removed
- **DO NOT** smoke in area when battery is being charged
- **ALWAYS** check for damage
- **DO NOT** use if damaged
- **DO NOT** work under the forks
- **DO NOT** lift more than the rated capacity
- **ENSURE** load is placed centrally over the forks
- **DO NOT** exceed rated capacity
- **DO NOT** use on ramps or gradients due to the possible excessive effort required and possibility of loss of control
- **DO NOT** use in insufficiently illuminated places
- **DO NOT** use to lift people
- **DO NOT** use as a vehicle jack
- **DO NOT** stand on fork ends
- **DO NOT** use for free swinging loads
- **AVOID** impairing stability
- **DO NOT** travel with the forks in the upper position except when loading or unloading operations
- **DO NOT** use extremities of forks as a lever to lift a load
- **DO NOT** use in an explosive atmosphere
- **DO NOT** allow the truck to come into direct contact with foodstuffs

Manual Handling Solutions 58, Paige Close, Watlington, Kings Lynn, Norfolk PE33 0TQ UK

Tel 0044 1553 811977 Fax 0044 1553 811004 sales@manualhandlingsolutions.co.uk www.manualhandlingsolutions.com

CHARGING

The stacker is proved with a separate electronic battery charger (in the tank) and this should be used to top up the battery charge regularly. The interval depends upon the extent of use.

CHARGER

- Supply 220/240 Volt 50 Hz 85 Watts
- Protected by automatic breaker
- Use 6 Amp fuse
- Outputs 4 Amp 12 Volt (6 Amp R.M.S.)

PROCEDURE FOR CHARGING

1. Connect the electronic battery charger to the socket on the top of the tank.
2. Switch on the battery charger.
3. Leave to charge.
4. Switch off the battery charger.
5. Disconnect the charger from the socket

IMPORTANT NOTES

The stacker should not be used during charging
The battery cannot be overcharged if the electronic charger supplied is used

OPERATING INSTRUCTIONS

- Control:** The electric pump and hydraulic circuits are controlled via 3 position lever (see diagram on tank top).
- Position 1 Lift:** In this position the hydraulic ram is extended causing the carriage to lift.
- Position 2 Lower:** In this position the carriage is lowered at a controlled speed.
- Position 3 Neutral:** This position causes the hydraulic circuit to close and hold the carriage position whether loaded or not.

OPERATION

The load should be distributed over the total length and width of the forks. The forks are lifted by jacking with the handle with the trigger pushed down. To lower squeeze the trigger. There is a central neutral position.

MAINTENANCE CHECKS AND ADJUSTMENTS

- DAILY:** The machine should be checked daily by the operator for obvious damage and faults should be reported.
- MONTHLY:** Check the oil and cable tension to make sure the chain has not become slack and for serious oil leaks (with hydraulic units some oil may escape around the cylinder which lubricates the seal, if in doubt check with engineer) and that the brake is in working order.
- ANNUALLY:** Check if the cable is stretched (this is normally carried out by Insurance Inspectors), check the mast and rollers and check the machine for damage. Check the wheels and bearings for wear.
- NOTE:** Keep the chain test certificate issued with this stacker in a safe place.
Modifications are not permitted

FILLING WITH OIL

The hydraulic pump is filled with TELLUS 22 or I.S.O. VG 22 EQUIVALENT. This oil is suitable for all normal use. If the stacker is required to work at low temperatures in freezer units, a freezer oil must be used. Please contact our office for advice. The oil level should be 20 mm below the filler plug when the stacker is in the fully lowered position. The stacker should be pumped to full height before replacing the filler plug. Cleanliness is essential when topping up.

SPARE PARTS - INITIAL EMERGENCY SPARES

QTY	PART NUMBER 1500 MM LIFT	PART NUMBER 2100 MM LIFT	DESCRIPTION
1	SP30-304	SP30-310	Lifting Chain and Wheel
1	WH30-508	WH30-508	Unbraked Swivel Castor
1	WH30-509	WH30-509	Braked Swivel Castor
1	OL18	OL18	Bottle of Hydraulic Oil
1	PH30-523	PH30-523	Set of Seals

NOTE: When ordering spare parts please specify the model, serial number and capacity.

FAULT FINDING

FAULT	REMEDY
Will not lift	Check that battery is fully charged. Check battery terminal.
Will not lift	Check oil level. This should be 20 mm below filler in lowered position.
Will not lift	Check lead from battery to motor

POWER LIFT PACK PARTS LIST

NOTE: It is recommended that only skilled service engineers service this unit. Instructions manuals are available on request. The power pack can be reconditioned, for details please contact your agent.

ITEM	1500MM LIFT PART NO	2100MM LIFT MODELS	QTY
S	PH30-523	PH30-523	1
130	PH30-527	PH30-528	1
131	HY500	HY499	1
132	HY612	HY612	1
133	SP30-307	SP30-307	1
134	SP30-303	SP30-303	1
135	FA63	FA63	1
140	F40-550	F40-550	1
141	F40-582	F40-582	1
142 *	PH40-584	PH40-584	1
143	E-591	E-591	1
144	E-593	E-593	1
145	UP/DOWN LABEL	UP/DOWN LABEL	1
146	SP30-308	SP30-308	1
147	E-598	E-598	1

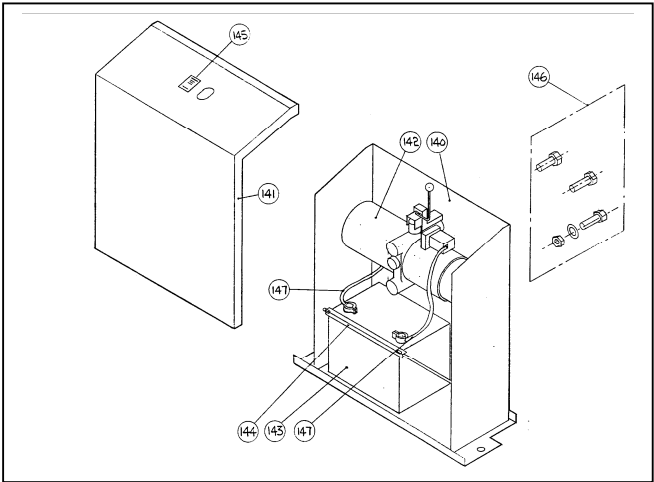

ET-CH-003 Euro plug Battery Charger for all models
ET-CH-004 UK plug Battery Charger for all models

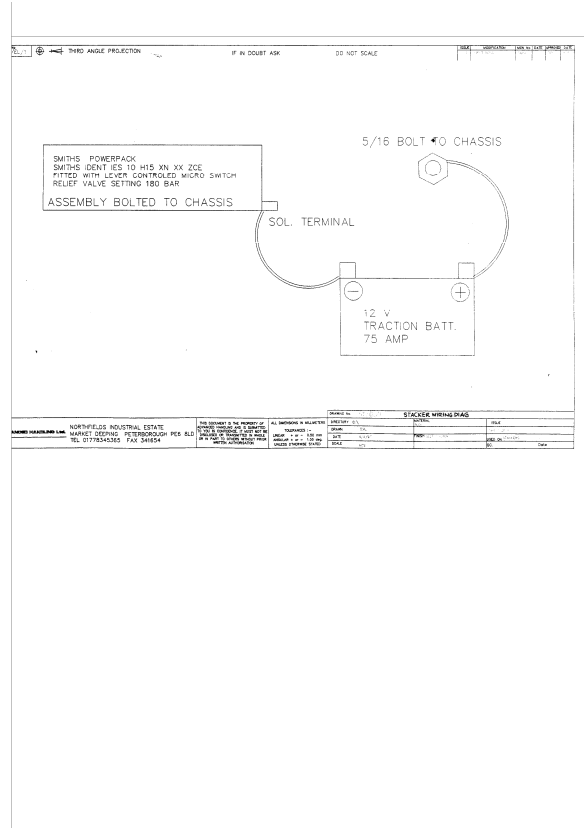
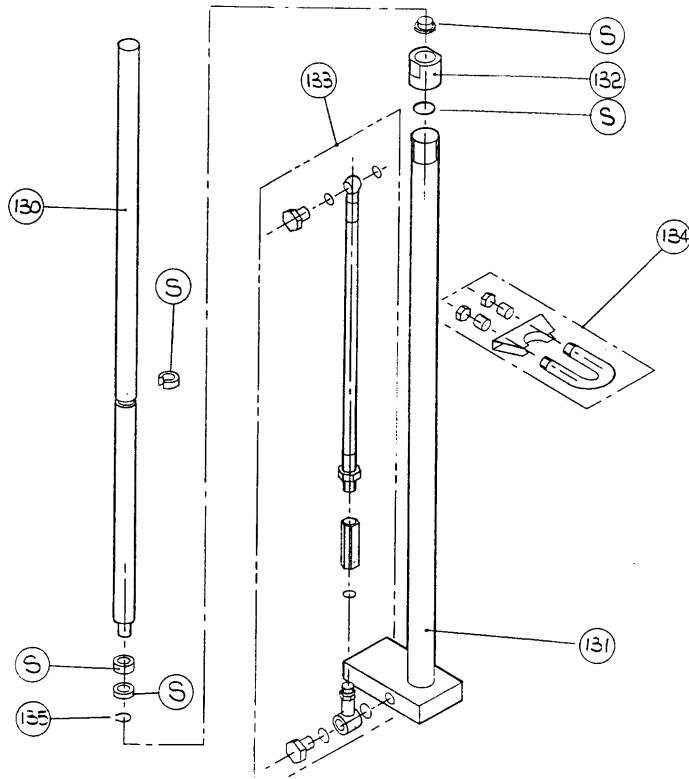

MAST & CARRIAGE ASSEMBLY

MAST & WHEELS

ITEM	PART NO WRAPOVER LEG	PART NO STRADDLE LEG	QTY
95	SP30-304	SP30-310	1
100	WH30-509	WH30-509	1
103	WH10-131	WH10-131	2
102	WH10-120	WH10-120	2
105	WH30-508	WH30-508	1

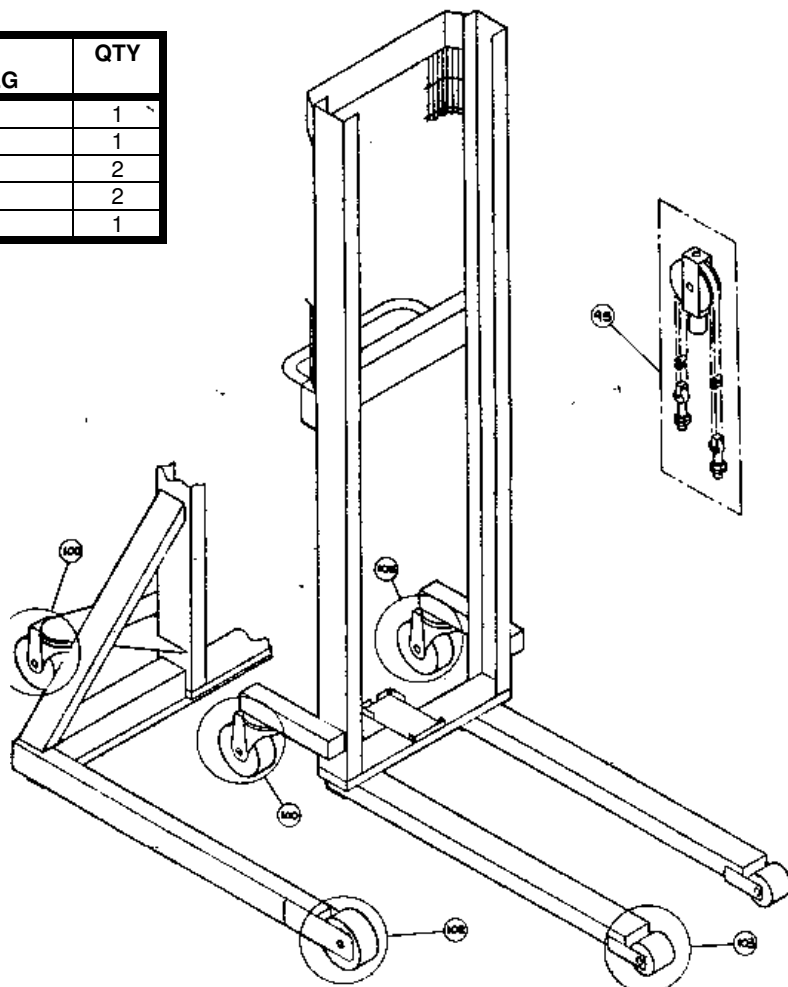

FIXED FORK CARRIAGE

ITEM	PART NO 700kg Cap Models	PART NO 1000kg Cap Models	QTY
110	SP30-305	WH30-532	4
111	F30-480	F30-479	1

ADJUSTABLE FORK CARRIAGE

ITEM	PART NO 700kg Cap Models	PART NO 1000kg Cap Models	QTY
110	SP30-305	WH30-532	4
120	F30-483	F30-200	1
121	F30-201	F30-201	1
122	FA55	FA55	4

