

SERVICE & PARTS MANUAL – MANUAL STACKER

MODELS	ST-500-1500-M	ST-500-1500-M-ADJ
	ST-500-2100-M	ST-500-2100-M-ADJ
	ST-1000-1500-M	ST-1000-1500-M-ADJ
	ST-1000-2100-M	ST-1000-2100-M-ADJ

IMPORTANT NOTICE

PLEASE PASS THIS LEAFLET TO YOUR SAFETY OFFICER BEFORE USE AND KEEP IT IN A SAFE PLACE.

READ THOROUGHLY BEFORE USE AND FAMILIARISE YOURSELF WITH THE TRUCK AFTER READING THESE INSTRUCTIONS.

TEST CERTIFICATES SHOULD BE PASSED TO THOSE RESPONSIBLE FOR YOUR REGISTER OF LIFTING EQUIPMENT AND BE RETAINED FOR SCRUTINY BY A FACTORY INSPECTOR, INSURANCE COMPANY ETC.

NO LIFTING GEAR SHOULD BE PUT INTO USE WITHOUT A VALID TEST CERTIFICATE, NOR USED BY UNTRAINED STAFF WHO ARE NOT FULLY AWARE OF THE INSTRUCTIONS FOR SAFE USE. ALWAYS WEAR SAFETY SHOES WHEN WORKING WITH THIS PRODUCT. THE USER SHOULD REFER TO EN 1005-3.

TECHNICAL DETAILS

	ST-500-1500-M	ST-500-1500-M-ADJ	ST-500-2100-M	ST-500-1500-M-ADJ
BUILT TO	BS EN 1757-1: 2001			
MAX CAP	500 kg	500 kg	500 kg	500 kg
LOAD CENTRE	500 mm	500 mm	500 mm	500 mm
FORK LENGTH	1140 mm	1000 mm	1140 mm	1000 mm
MAX LIFT HEIGHT	1500 mm	1500 mm	1500 mm	1500 mm
WEIGHT	159 kg	179 kg	199 kg	213 kg

	ST-1000-1500-M	ST-1000-1500-M-ADJ	ST-1000-2100-M	ST-1000-1500-M-ADJ
BUILT TO	BS EN 1757-1: 2001			
MAX CAP	1000 kg	1000 kg	1000 kg	1000 kg
LOAD CENTRE	500 mm	500 mm	500 mm	500 mm
FORK LENGTH	1140 mm	1000 mm	1140 mm	1000 mm
MAX LIFT HEIGHT	1500 mm	1500 mm	1500 mm	1500 mm
WEIGHT	270 kg	330 kg	330 kg	360 kg

HANDLING & OPERATION

If delivered on a vehicle it should be lifted by crane, or if lifted by forklift secure to carriage. Check that it is secure before removing from a vehicle. This stacker was designed only to be used on flat, smooth firm ground.

UNFORESEEN USE

- **ALWAYS** check for damage
- **DO NOT** use if damaged
- **DO NOT** work under the forks
- **DO NOT** lift more than the rated capacity
- **ENSURE** load is placed centrally over the forks
- **DO NOT** exceed rated capacity
- **DO NOT** use on ramps or gradients due to the possible excessive effort required and possibility of loss of control
- **DO NOT** use in insufficiently illuminated places
- **DO NOT** use to lift people
- **DO NOT** use as a vehicle jack
- **DO NOT** stand on fork ends
- **DO NOT** use for free swinging loads
- **AVOID** impairing stability
- **DO NOT** travel with the forks in the upper position except when loading or unloading operations
- **DO NOT** use extremities of forks as a lever to lift a load
- **DO NOT** use in an explosive atmosphere
- **DO NOT** allow the truck to come into direct contact with foodstuffs

ASSEMBLY

This product is normally assembled before delivery.

OPERATION

The load should be distributed over the total length and width of the forks. The forks are lifted by jacking with the handle with the trigger pushed down. To lower squeeze the trigger. There is a central neutral position.

MAINTENANCE CHECKS AND ADJUSTMENTS

- DAILY:** The machine should be checked daily by the operator for obvious damage and faults should be reported.
- MONTHLY:** Check the oil and cable tension to make sure the chain has not become slack and for serious oil leaks (with hydraulic units some oil may escape around the cylinder which lubricates the seal, if in doubt check with engineer) and that the brake is in working order.
- ANNUALLY:** Check if the cable is stretched (this is normally carried out by Insurance Inspectors), check the mast and rollers and check the machine for damage. Check the wheels and bearings for wear.
- NOTE:** Keep the chain test certificate issued with this stacker in a safe place.
Modifications are not permitted

FILLING WITH OIL

The hydraulic pump is filled with TELLUS 22 or I.S.O. VG 22 EQUIVALENT. This oil is suitable for all normal use. If the stacker is required to work at low temperatures in freezer units, a freezer oil must be used. Please contact our office for advice. The oil level should be 20 mm below the filler plug when the stacker is in the fully lowered position. The stacker should be pumped to full height before replacing the filler plug. Cleanliness is essential when topping up.

SPARE PARTS - INITIAL EMERGENCY SPARES

QTY	PART NUMBER 1500 MM LIFT	PART NUMBER 2100 MM LIFT	DESCRIPTION
1	SP30-304	SP30-310	Lifting Chain and Wheel
1	WH30-508	WH30-508	Unbraked Swivel Castor
1	WH30-509	WH30-509	Braked Swivel Castor
1	OL18	OL18	Bottle of Hydraulic Oil
1	PH10-288	PH10-288	Set of Seals

NOTE: When ordering spare parts please specify the model, serial number and capacity.

FAULT FINDING CHART

FAULT	CAUSE	REMEDY
Will not lift or lift to full height	Trigger not in 'lift' position	Push trigger fully down into 'lift' position
If fault remains	Air in pump	Ten strokes with trigger 4 in lower position
If fault remains	Release valve continuously open	Slacken off item 76
If fault remains	Oil level too low	Fill as instructions
If fault remains	Ram seal damaged	Remove item 51 check for wear
If fault remains	Dirty or damaged ball valve	Remove item 68 or 63 check for scoring, if damaged replace. Reseat ball 68 and replace
Lifts only a small amount on each stroke	Vacuum in pump	Take out item 23 to allow air to enter. Replace item 23
Lifts when handle is pulled down but lowers when handle returned to upright position	Release ball not seating	Remove items 56, 65, 31, 73, clean and reseat 73 by tapping onto seat
Forks sink slowly with trigger released	Truck release valve in operation	Slacken off nut item 76
Lowering slowly (please allow sufficient time for seals to be in)	Release valve not fully open	Tighten nut 76 not too far or the truck will not lift

PUMP UNIT

ITEM	PART NO	QTY	ITEM	PART NO	QTY	ITEM	PART NO	QTY
3	L10-080	1	28	PH10-213	1	62	PH10-211	1
4	L10-094	1	30	PH10-241	2	63	-	1
5	L10-079	1	31	-	1	64	-	1
6	L10-096	1	32	+ -	1	65	-	1
7	L10-072	1	40	L10-075	1	66	-	1
8	L10-073	1	41	FA59	1	68	-	1
11	L10-085	1	44	FA50	1	70	BN10-078	2
12	PH30-543 (1500mm Lift Models) PH30-544 (2100mm Lift Models)	1	45	FA53	1	72	PH10-246	1
14	PH10-233	1	46	+ -	2	73	-	1
15	+	1	47	+ -	1	75	FA65	1
17	L10-077	1	48	+	1	76	BM56	1
18	PH10-217	1	50	+	1	77	FA63	1
20	PH10-270	1	51	+	1	79	-	2
21	+	1	52	+	1	80	L10-076	1
22	PH30-515 (1500mm Lift Models) PH30-525 (2100mm Lift Models)	1	53	PH10-224	2	81	+	1
23	PH10-252	1	55	+	1	82	HY629	1
24	PH10-228	1	56	-	1	83	PH10-243	1
26	L20-309	1	57	+ -	1	105	SP30-309	1

+ Seal Kit available PH10-288

- Cassette Valve Kit available PH10-296

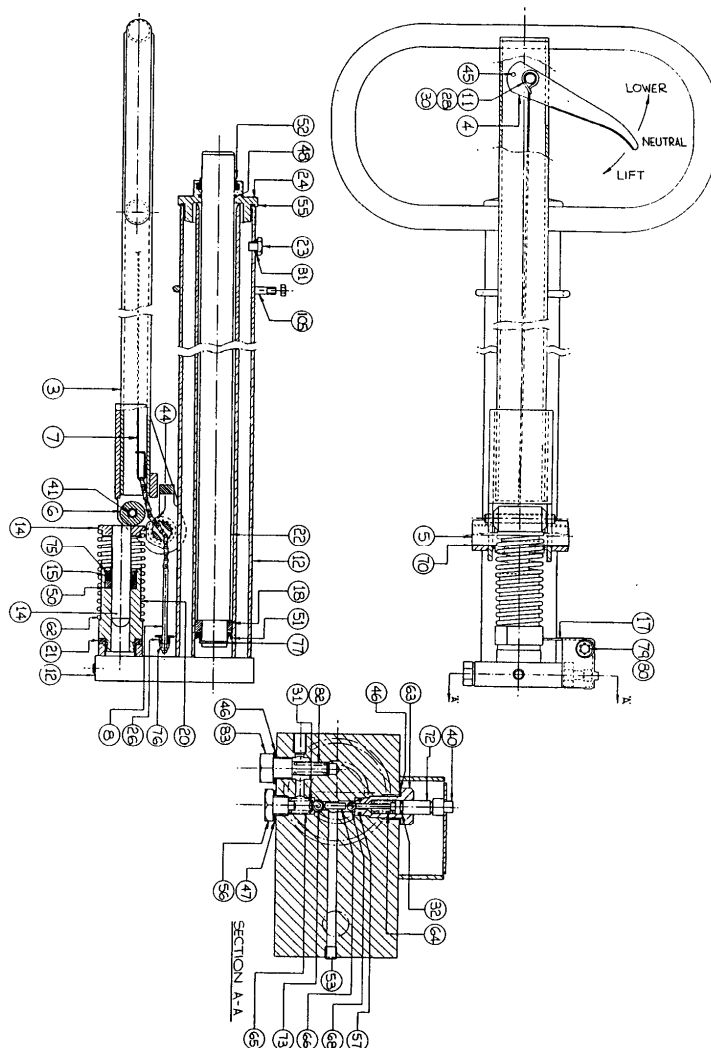

STP_1

(11/94)

MAST & CARRIAGE ASSEMBLY

MAST & WHEELS

ITEM	PART NO 1500MM LIFT	PART NO 2100 MM LIFT	QTY
95	SP30-304	SP30-310	1
100	WH30-509	WH30-509	1
103	WH30-131	WH30-131	2
102	WH10-127	WH10-127	2
105	WH30-508	WH30-508	1

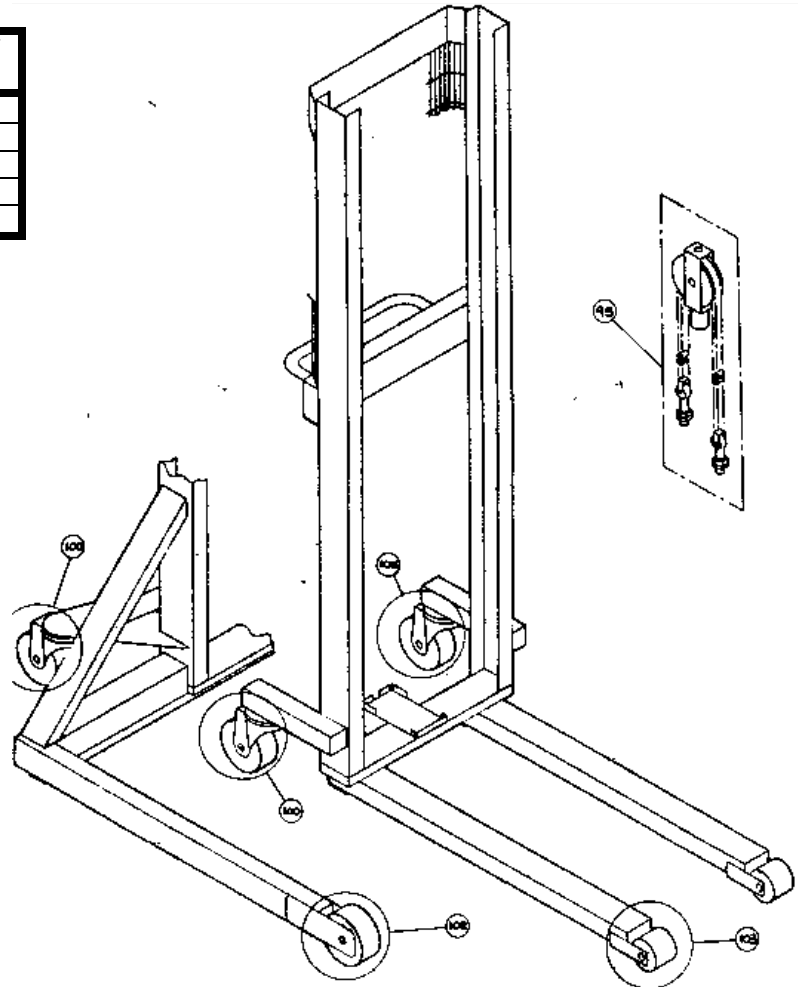

FIXED FORK CARRIAGE

ITEM	PART NO 500kg Cap Models	PART NO 1000kg Cap Models	QTY
110	WH30-530	WH30-532	4
111	F30-480	F30-479	1

ADJUSTABLE FORK CARRIAGE

ITEM	PART NO 500kg Cap Models	PART NO 1000kg Cap Models	QTY
110	SP30-305	WH30-532	4
120	F30-483	F30-200	1
121	F30-201	F30-201	1
122	FA55	FA55	4

