

SERVICE & PARTS MANUAL – MOBILE SCISSOR TABLE

MODEL SC-125-D-M / SC1125

IMPORTANT NOTICE

PLEASE PASS THIS LEAFLET TO YOUR SAFETY OFFICER BEFORE USE AND KEEP IT IN A SAFE PLACE.

READ THOROUGHLY BEFORE USE AND FAMILIARISE YOURSELF WITH THE TRUCK AFTER READING THESE INSTRUCTIONS.

TEST CERTIFICATES SHOULD BE PASSED TO THOSE RESPONSIBLE FOR YOUR REGISTER OF LIFTING EQUIPMENT AND BE RETAINED FOR SCRUTINY BY A FACTORY INSPECTOR, INSURANCE COMPANY ETC.

NO LIFTING GEAR SHOULD BE PUT INTO USE WITHOUT A VALID TEST CERTIFICATE, NOR USED BY UNTRAINED STAFF WHO ARE NOT FULLY AWARE OF THE INSTRUCTIONS FOR SAFE USE.

TECHNICAL DETAILS

BUILT TO:	EN1570
TYPE:	SC-125-D-M Manual Hydraulic Operated Scissor Table
MAX CAPACITY:	125 kg
TOP SIZE:	500 mm x 840 mm
CLOSED HEIGHT:	430 mm
RAISED HEIGHT:	1420 mm
HANDLE HEIGHT:	860 mm

HANDLING

This product weighs 85 kg. There are no special handling requirements. The table must not be inverted or put on its side.

SAFETY

This table has been built to BS 5323 and every table is accompanied by a Test Certificate. **Please** read and **Keep** it in a safe place. You may be asked to present it by your insurance company or factory inspector. For safety the table has been designed to give:-

- 30mm gap between the arms.
- 50mm gap between the arms and frame.
- Flow control cartridge in ram. Even if the hydraulic hose is cut the table will still descend at a safe speed.
- Automatic stop lowering if the pedal is released.
- If the slow lowering cartridge happens to become activated, an investigation needs to be carried out to determine the cause.

IT IS DANGEROUS TO WORK UNDER THE TABLE TOP WHEN THE PLATFORM IS IN THE RAISED POSITION.

ONLY AUTHORIZED PERSONS SHOULD BE ALLOWED TO OPERATE THIS TABLE

SAFETY SHOES SHOULD BE WORN WHEN USING THE PRODUCT

ANY DAMAGE, OR IF THE TABLE DOES NOT PERFORM CORRECTLY, SHOULD BE REPORTED IMMEDIATELY AND USE DISCONTINUED.

UNFORESEEN USE

- **DO NOT** use on ramps or slopes, only on flat surfaces
- **ALWAYS** check for damage. Any damage or fault should be reported immediately
- **DO NOT** use if damaged or faulty
- **DO NOT** work under the table top when the platform is in the raised position
- **DO NOT** remove warning labels
- **DO NOT** lift more than the rated capacity
- **ALWAYS** apply the brake when stationary
- **ENSURE** people are clear of the table before lowering
- **ENSURE** that the table is fully secure during maintenance as it may fall if knocked or moved
- **BEWARE** that fingers could be trapped when lowering the table lid

Please note we strongly advise against the use of this product in wet or damp conditions.
If you do need to use this product in a wet or damp environment please contact Customer Services.

LOADING THE TABLE TOP

This table has been manufactured and tested to take the full load spread over the table top. Half the load over half the platform length, one third of the load over one half of its width. **This loading must not be exceeded.**

Raising: The table lifts by operating the foot operated jacking pedal.
Lowering: The table is lowered by operating the lowering pedal. The oil passes through a flow control cartridge and this slows the lowering speed, irrespective of the load on the table.

ASSEMBLY

This product is normally assembled before delivery.

DISPOSAL OF PRODUCT

Once the product has completed its working life, contact your local authority to dispose of it in the correct manner.
(Materials used to build the table : Steel, Plastic, Oil)

MAINTENANCE CHECKS & ADJUSTMENTS

With table fully lowered, the top hinges to allow access to the hydraulics.
All hinged points have nylon bearings and the ball races are sealed, therefore, little maintenance should be required.

- Daily:** The machine should be checked daily by the operator for obvious damage and oil leaks. Faults should be reported.
- Monthly:** Check the oil for serious oil leaks (with hydraulic units some oil may escape around the cylinder which lubricates the seal, if in doubt check with engineer). Check that the brake is in working order.
- Annually:** The table should be re-tested.
- Note:** Table should be re-tested after any repair work has been carried out.

FILLING WITH OIL

The hydraulic pump is filled with TELLUS 22 or ISO VG22 equivalent.

It will be necessary to top up the hydraulic oil occasionally via the filler. Only fill with enough oil to allow the table to lift to full height - overfilling will cause leakage. To top up with oil, adjust the mechanism or work on any part of the pump, the table should be completely lowered and the top hinged back for access to the hydraulic systems.

SPARE PARTS – INITIAL EMERGENCY SPARES

QTY	PART NO	DESCRIPTION
1	WH20-312	Braked Castor Bracket
1	WH20-311	Unbraked Castor Bracket
1	OL18	Bottle of Hydraulic Oil
1	PH10-290	Set of Seals
2	WH20-210	Polyurethane Wheel

IMPORTANT: When ordering spare parts please specify the model, serial number and capacity.

PUMP UNIT SC-125-D-M

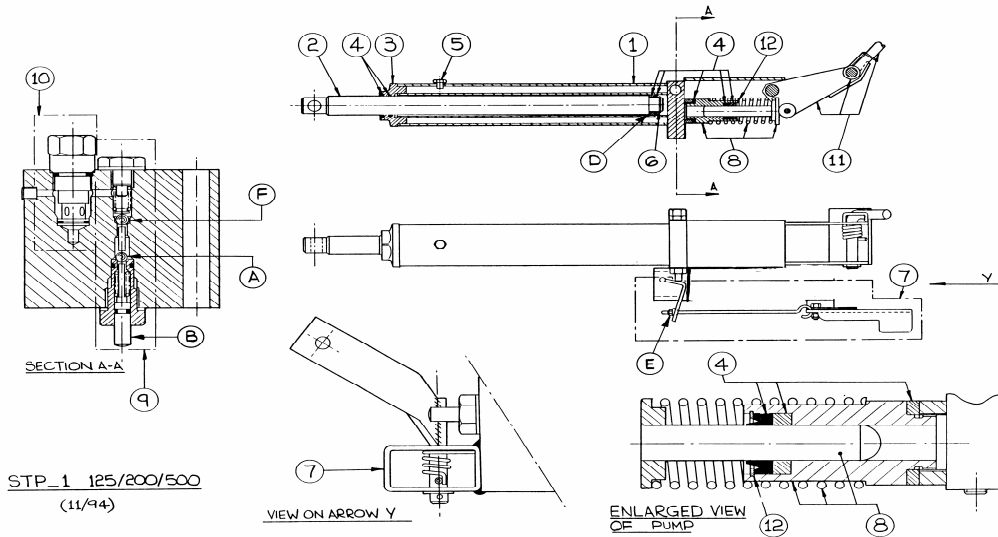

ITEM	PART NO	QTY	ITEM	PART NO	QTY
1	SP20-300	1	7	L20-330	1
2	PH20-302	1	8	PH20-412	1
3	PH10-228	1	9	PH10-296	1
4	PH10-290	1	10	HY625	1
5	PH10-224	1	11	L20-251	1
6	FA63	1	12	FA65	1

FAULT FINDING CHART

FAULT	CAUSE	REMEDY
Will not raise when jacking	Air in hydraulics	Keep the lowering lever pressed down while jacking
If fault remains	Suction ball "A" not seating	Lower the table fully, hinge lid up, make sure plunger "B" is coming fully out and moves correctly
If fault remains	Suction ball "A" not seating	Unscrew nut "E" a few turns
Does not jack to full height	Air in hydraulics	Keep the lowering lever pressed down while jacking
If fault remains	Not enough hydraulic oil	Lower fully, hinge lid, check oil level
Will not lift full capacity	Load too heavy	Check weight of load
Sinks slowly	Seal damaged	Remove pump, remove cap 3 and ram 2, change seal "D"
If fault remains	Ball not seating	Reseat ball "F"
Table raised and lower on each jack	Air in hydraulics	Keep the lowering lever pressed down while jacking
If fault remains	Ball not seating	Reseat ball "F"

- Do not disturb overload valve (item 6)
- The table top hinges when the table is fully lowered for access
- Do not jack with the table lifted
- The pump and ram can be removed together with the hose for replacement or service

MODEL SC-125-D-M

ITEM	PART NO	QTY	ITEM	PART NO	QTY
1	BE10-071	4	17	BM304	4
4	FA81	2	18	FA54	2
7	BM305	4	19	FA62	4
8	BM306	10	25	L20-305	1
9	BM520	4	26	L20-306	1
10	BM521	4	1	WH20-210	4
11	BN20-307	10	33	WH20-311	1
15	BW303	12	34	WH20-312	1
16	F20-301	1	35	L20-318	1

