

# Manual Scissor Lift Table



# Manual Scissor Lift Table

## Contents

18	Introduction Safety Regulations Use Scope of Delivery Warranty and Conditions of Delivery
19	Responsibility Max load = Evenly distributed load
20	Installation
21	Rated Current Fuse Lowering Speed Controller for standard functions
22	Installation of the lift table on the floor or in a pit Pit Drawing
23	Hydraulic system Electrical system
24	Mechanical Design
25	Maintenance and Service
26	Lubrication Points
27 - 28	Fault tracing
29	Oil Recommendations Loading and Unloading Enclosed Appendices
30	Wiring Diagram
31	Hydraulic Diagram

# Manual Scissor Lift Table

## Introduction

**IMPORTANT!** Read through the manual before using the lift table! The manual provides assistance for the safe usage of the lift table and to attain high operating reliability and a long life.

Only authorised personnel may use the lift table.

The manual describes the intended method of use for the lift table. The manufacturer bears no responsibility for damage or loss if the lift table has been used in a way other than that described in this manual!

## Safety Regulations

All of our lift tables conform to the safety regulations for lift tables in Europe. The CE-mark on our tables states that the products conform to applicable EU Directives.

All tables feature an integrated safety function in the pinch guard frame, which means if the safety frame trips on the downward travel the table stops immediately. The UP button must first be pressed to reset the downward travel in order to continue lowering.

The lift table is always delivered as standard with a "deadman's grip" controller, which means that when either the UP or DOWN buttons are released the table stops immediately. The controller is also equipped with an emergency stop function and in some designs also with a lock.

**NOTE! When the lift tool is used in areas where children can be, for example, schools, shops, etc. the machine's working area must be cordoned off or other actions must be taken to prevent accidents.**

## Use

The lift table is designed for use on a flat and firm surface, and can be placed directly on the floor or lowered in a pit. The surface must have sufficient load carrying capacity for the lift table including load. We recommend that all stationary lift tables are bolted to the floor to avoid unintentional movement if hit. Anchorage may also be an unconditional demand to avoid overturning, for example, when the table is equipped with a tilt mechanism or equipped with additional scissors.

## Scope of Delivery

The lift table is delivered first after extensive inspection and testing. The hydraulic oil is included in the delivery.

Electrical equipment is as standard designed for connection to 3-phase, 400 V, 50 Hz with 24 V on the controller, solenoid valve, pinch frame, limit position, etc.

The lift table is finished in the following colours:

Blue = RAL 5017

Black = RAL 9005

Red = RAL 3020

## Warranty and Conditions of Delivery

General conditions of delivery within the Nordic Countries NL 01.

# Manual Scissor Lift Table

## Responsibility

**The installation engineers and employer** must ensure that the risk of crushing cannot arise during the installation of the lift equipment.

**The employer** is obliged to ensure that the equipment is used by skilled personnel and that inspection and maintenance of the equipment is carried out as necessary.

**Furthermore, it is incumbent on the employer to ensure:**

- that the max load on the lift equipment is not exceeded. That the load is secured - must not start rolling.  
MAX LOAD = EVENLY DISTRIBUTED LOAD (see below)
- check the function of the pinch guard frame and the pinch risk distance around the equipment.
- that statutory warning decals are maintained.
- check for possible load damage to the lift equipment.
- check and maintain cables and hoses.
- check for signs of leakage and spreading.
- that the main power switch is accessible to authorised personnel. The equipment must not be used by unauthorised persons.
- that lift tables designed for outdoor use are equipped with slip protection according to applicable safety regulations.
- that tilting table-tops are equipped with guards to secure the load.
- that the conveyance of passengers only takes place on lift tables designed for this purpose - see the table rating plate.

---

## MAX LOAD = EVENLY DISTRIBUTED LOAD

**Note that the maximum load refers to a load placed evenly distributed across the entire table top.**  
According to the lift table standard SS-EN 1570 fundamental demands are:

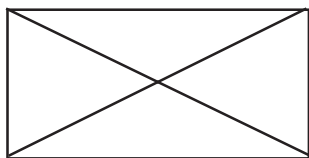

100 % of the rated load distributed across the entire table top

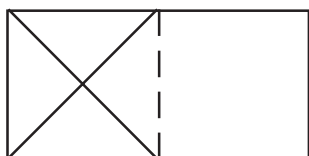

or 50 % of the rated load distributed lengthways over half of the table surface

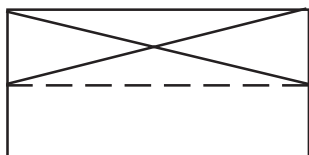

or 33 % of the rated load distributed sideways over half of the table surface

# Manual Scissor Lift Table

## Installation

The table must **ALWAYS** be in the locked position during installation, repair or inspection under or next to a raised table.





The electrical installation must be carried out by qualified electricians and the mechanical installation must be carried out by skilled personnel.

The main power switch must be installed and accessible to authorised personnel during operations. Check that the lift table's connection voltage corresponds with that of the mains supply, and that supply cables and fuses match the output requirement of the lift table.

The controller must have an emergency stop function according to EEN 60204. If an extra controller must be connected, it must be done in series besides the emergency stop function which is connected in parallel. A 6-core cable is required for this connection.

If the controller is fitted on the table, a separate emergency stop must be fitted next to the table.

**NOTE! The table must ALWAYS be unloaded during installation.**

<p><b>1</b></p>  <p><b>Unpacking</b> Check the packaging to ensure that no transport damage has occurred. The electrical cable for temporary connection is on the short side, except on the long scissor table where the cable is on the long side.</p>	<p><b>2</b></p>  <p><b>Do not lift from the pinch guard frame</b> Deformation and functional problems can occur. (The table lifts but does not lower)</p>
<p><b>3</b></p>  <p><b>Connect the connection plug</b> The supply cable for the incoming power on the table in the standard designs is 4-core and consists of 3 phases + ground.</p>	<p><b>4</b></p>  <p><b>Connect to the power</b></p>
<p><b>5</b></p>  <p><b>Take hold of the controller</b> Run up the table using the UP button. Does the motor start, but the table does not lift? Switch two phases. (It is important that the motor is not run too long in the wrong direction, as this can damage the pump)</p>	<p><b>NOTE!</b> The connection plug, motor cut-out and main power switch are not included as standard in our delivery.</p>

**Lock the table! The table must ALWAYS be in the locked position during installation, repair or inspection under or next to a raised table.**

# Manual Scissor Lift Table

## Rated Current

Check the type of hydraulic unit, current type and rated output on the motor.

E = Rated output on the motor

MS = Rated Current

IS = Installation fuse

Unit type	230V 3-phase			400V 3-phase			500V 3-phase		
	E (kW)	MS (A)	IS (A)	E (kW)	MS (A)	IS (A)	E (kW)	MS (A)	IS (A)
Micro unit	0.8	4.3	10	0.8	2.5	10	0.8	2.0	10
Mini unit	2.3	8.5	20	2.3	5.0	10	2.3	4.0	10
Mini unit	--	--	--	3.5	9.0	20	3.5	7.2	16

Unit type	110V 1-phase			230V 1-phase		
	E (kW)	MS (A)	IS (A)	E (kW)	MS (A)	IS (A)
Micro unit	0.8	11.2	25	0.8	5.4	16
Mini unit	2.3	21.0	50	2.3	10.6	20

## Fuse

2A Slow burn (5x20mm)

The electrical equipment has fuse protected 24 V out to protect the circuit board.

## Lowering Speed

Max. 0.15 m/s

**Important!** If the lowering speed is too high, the hose rupture valve in the cylinder can trip. The table then stops completely or lowers very slowly.

## Controller for standard functions

Our lift table is equipped with an emergency stop function on the controller. Pressing the emergency stop button stops all electrically controlled movement on the table. Once the cause of the emergency stop has been established and rectified, turn the stop button clockwise to reset. The UP bottom must first be pressed to reset the downward travel in order to lower the table after an emergency stop.

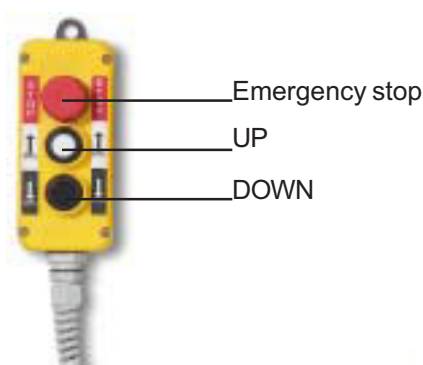
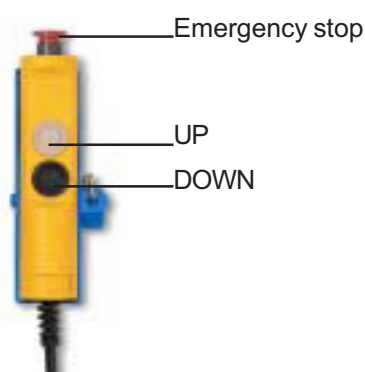

# Manual Scissor Lift Table

## Installation of the lift table on the floor or in a pit.

Stationary double and triple vertical tables must be bolted to the floor or the like. We also recommend that all other types of stationary lift tables are bolted to the floor in order to prevent unintentional movement.

## Assembly

1. On standard models the lift table's bottom frame is not self-supporting. It is therefore important for the installation that the floor is flat and that the pit has a smooth surface and is well drained if necessary.
2. Take out the controller and supply cable.
3. Lift the table into position. Turn the fixed side in the direction that the goods will be driven on and off in the uppermost position. UNSCREW THE LIFTING EYES IF FITTED.
4. Raise and lock the table. Connect the stationary cables.
5. Electrical installation must be performed by qualified electricians.
6. Test the function of the pinch guard frame on all sides. Adjust if necessary.
7. Secure the table if necessary to the floor or in the pit using expansion shell bolts or the like. See the securing proposal.

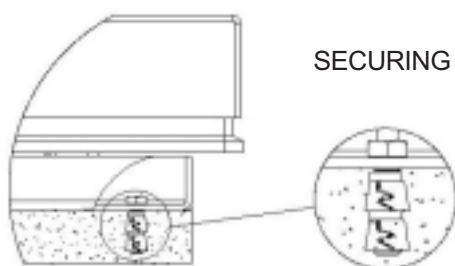

SECURING PROPOSAL

Fasteners are not included in the table delivery.

## Pit Drawing

- A. Pit length =  $a + 30\text{mm}$
- B. Pit width =  $b + 30\text{mm}$
- H. Pit depth = table's lowest height + 5mm
  
- a. Overall table length
- b. Overall table width
  
- x. Drainage hole (where required)
- y. Pipes for incoming media 80mm in diameter

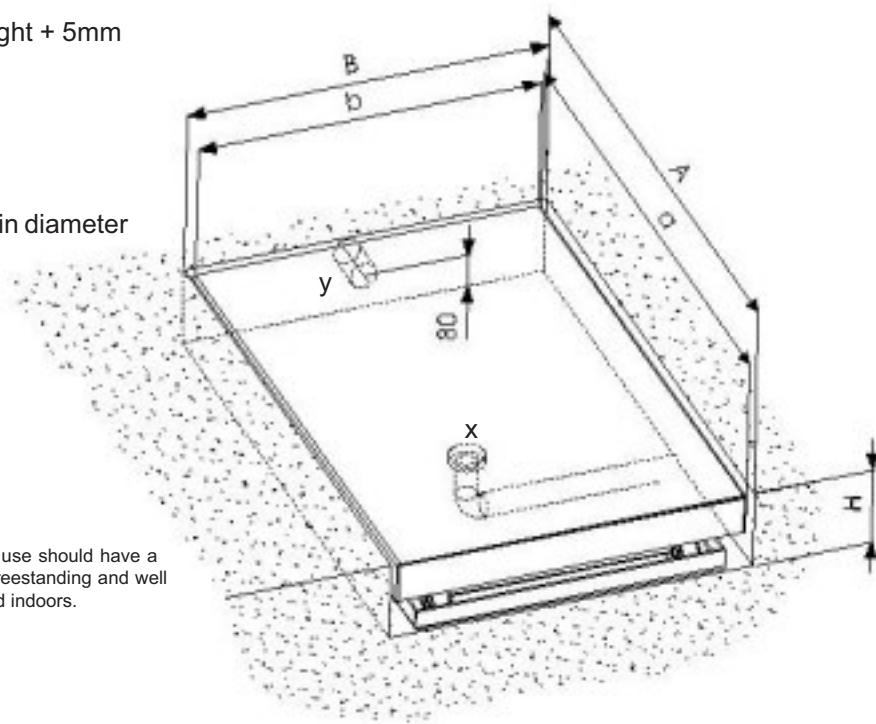

Lift tables for outdoor use should have a hydraulic unit that is freestanding and well protected or positioned indoors.

# Manual Scissor Lift Table

## Hydraulic system

Our hydraulic lift table features an integrated or freestanding hydraulic unit as standard. The hydraulic system is single/double-acting and is designed according to the enclosed hydraulic diagram.

The hydraulic system consists of the following main parts:

- **Hydraulic tank**
- **Hydraulic pump**
- **Hydraulic cylinder**

There are also a number of other valves including an overflow valve, non-return valve and a hose rupture valve. Hydraulic oil is transported between all of these components.

In order for the hydraulic system to perform at its best, always requires:

- **Right hydraulic oil**
- **High level of cleanliness**

---

## Electrical System

Before connecting the lift table to the mains supply, check that the voltage of the motor and the distribution box correspond with the mains supply.

NOTE! Electrical connection and any fault tracing must be performed by qualified electricians.

Our lift table is supplied as standard for connection to 3-phase/400V/50Hz.

The standard distribution box on the hydraulic unit contains:

- Contactors
- Transformer for supplying 24 V alternating voltage to the control system
- Fuse for the transformer's secondary circuit
- Control card with terminal blocks
- Rectifier for solenoid valves

The main power switch and motor protection relay are not included in the delivery, but must be fitted by the installation engineer. The supply cable is connected to the terminal block or directly to the contactors.

The wiring diagram can be found inside the distribution box and is enclosed with this instruction.

# Manual Scissor Lift Table

## Mechanical Design

The mechanical design is made up of the following main parts:

- Bottom frame (1)
- Inner scissors (2)
- Outer scissors (3)
- Bearing mounted axle (4)
- Table top (5)
- Bearing mounted roller (6)
- Work lock (7)
- Pinch guard frame (8)

The bottom frame must be bolted to the floor. In doing so creates the conditions for stable and safe working conditions.

The inner and outer scissors are joined by a bearing mounted axle. The inner scissors are fastened on the lower edge of the bottom frame by a bearing mounted axle, while the top supports the table top via a bearing mounted roller.

The outer scissors are fastened to the top edge of the table by a bearing mounted axle. On the lower end the scissors run on the bottom frame by means of a bearing mounted roller.

The design using a roller at one end and a fastening at the other ensures a stable support can always be guaranteed, as the height of the table changes.

The lift table is equipped with a safety frame under the outer sections of the table top to protect against pinch injuries. This stops the lowering travel when pressed and in order to continue lowering the UP button must first be pressed, reset function.

**The scissors must always be locked using the work lock during all adjustment and repair work.**

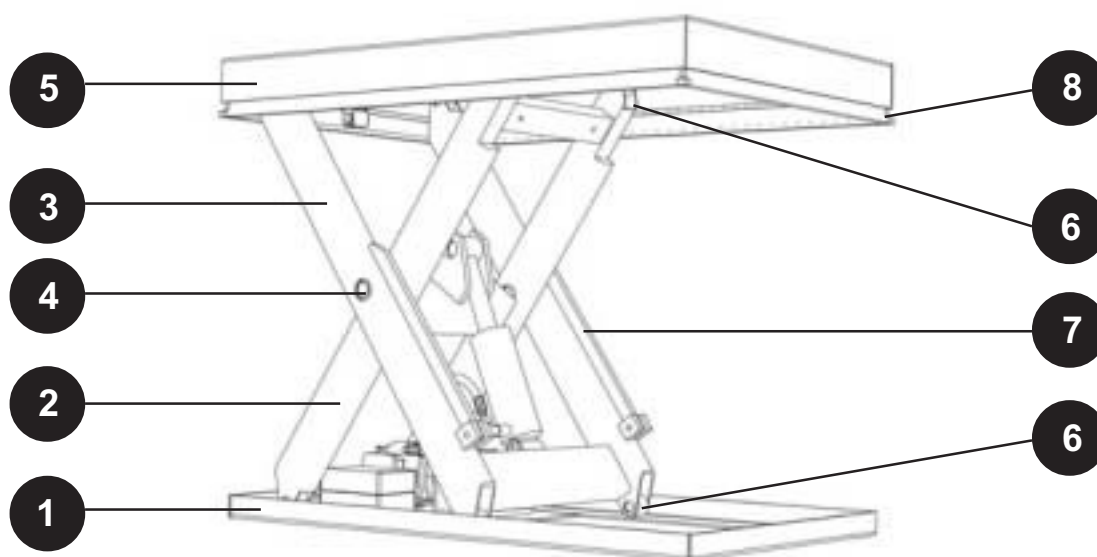

# Manual Scissor Lift Table

## Maintenance and Service

Regular maintenance and service are very important in order to eliminate deficiencies and unnecessary downtime. **The manufacturer bears no responsibility for the consequences should these instructions be disregarded.**

Important! Ensure that operators that come into contact with the lift table have been instructed how the lift table works and the risks involved with maintenance and service.

**Inspection, service and repairs must be performed by skilled personnel.**

**Remove any load on the top. Service locks must be placed in the locked position. Disconnect the main power supply before starting work on the electrical system.**

## Weekly maintenance

- **Check the oil** - remember the maximum volume in the tank is when the table is fully lowered. Look for any oil leakage and ensure that spilt hydraulic oil is handled as environmental hazardous waste.
- **Pinch guard frame** - during lowering, press up the pinch guard frame and the table should stop immediately once the pinch guard frame is activated. This should be done on all sides of the lift table.
- **Axle fastening** - check that all axles are fastened correctly. Otherwise secure the locking screw for the axle using "Loctite".
- **Axle lubrication** - the lubrication of bearings in cylinders **MUST** be done at least every 3000 work cycles. All other bearings with grease nipples should be lubricated every 500 working hours. Other joints are lubricated with grease as required. (lubrication points see page 26).
- **Cleaning** - clean the lift equipment (roller surfaces, etc.). Ensure that the decals are legible.

## Monthly maintenance

- **Cables and electrical connections** - check that no cables are loose, have damaged connectors or are damaged. If a cable connection is damaged, ensure qualified personnel rectify the fault.
- **Hydraulic hoses** - check that oil leakage not occur from connections and that the connections are not damaged in any way. If a hose or connection is damaged, ensure that a hydraulic engineer rectifies the fault.
- **Overloading** - check for any damage due to overloading.

## Annual maintenance

- **Bearings** - check for signs of abnormal play on the bearings. If there is play on a bearing, both the bearing, axle and bushing must be replaced.

# Manual Scissor Lift Table

## Lubrication Points

The table's bearings must be offloaded when lubricating. When checking the oil, remember the maximum volume in the tank is when the table is fully lowered. Remember to handle spilt hydraulic oil as environmental hazardous waste.

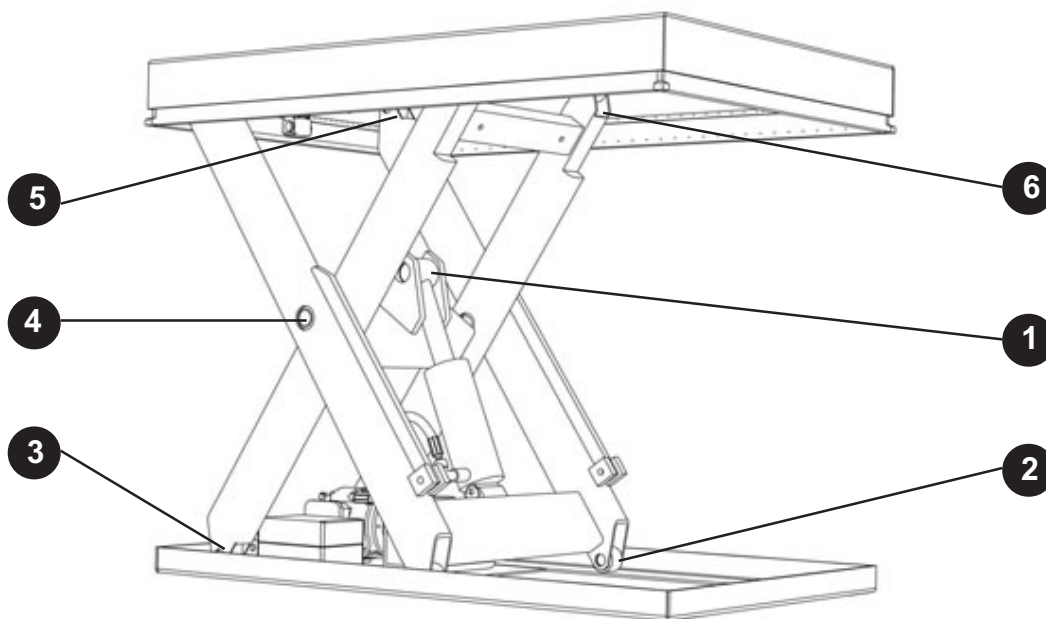

1 Piston rod bearing

4 Centre axle

2 Lower scissor roller

5 Upper scissor fastening

3 Lower scissor fastening

6 Upper scissor wheel

**Position 1 applies to all table - a check MUST be made regularly (weekly)  
Position 2 - 6 only applies to tables in a special design (Hard-Drive, etc.)**

**THE MANUFACTURER BEARS NO RESPONSIBILITY FOR THE  
CONSEQUENCES SHOULD THESE INSTRUCTIONS BE DISREGARDED!**

# Manual Scissor Lift Table

## Fault tracing

Repair, maintenance and fault tracing may only be performed by skilled personnel. Contact the manufacturer if assistance is required or if the fault cannot be rectified.

**NOTE! The table should ALWAYS be locked during service and repair work.**

A complete load and operating test must be made after major repair work.

Fault	Cause	Action
The motor does not start	Main power switch off	Switch on the switch
	No voltage	Check the supply voltage and amperage on all phases on the motor
	STOP button pressed in	Turn the button anticlockwise
	Supply voltage and fuses	Replace any blown fuses
No lift movement	Motor rotates in the wrong direction	Switch two phases. It is important that the motor does not run in the wrong direction, as this can damage the pump. NOTE! Check that the main power switch is switched off before the work is started.
	Incorrect electrical connection	Check the connections
	Motor stops	Lift overloaded. Remove the excess load.
	The table can not lift the max load	1) Check the amperage on all phases on the motor. 2) Adjust the pressure control valve. Adjust to a load corresponding to the table's max load. Test the pressure with a pressure gauge.
	Other cause	Contact the manufacturer
Lift doesn't reach the upper position	Insufficient oil volume	Check the oil level in the tank. Top up if necessary with the recommended oil, however not more than the upper position is reached. Too much oil can cause oil flow out of the tank when lowering.
	Overload	Check that the max load is not exceeded. Remove the excess load.
	Upper limit position sensor	Adjust the max. sensor.

# Manual Scissor Lift Table

<b>Fault</b>	<b>Cause</b>	<b>Action</b>
Jerky lift or lowering travel	Air in the hydraulic system	Check the oil level in the tank. NOTE! The tank must not be filled when the table is in the raised position. Bleed the system by running the table up and down 4 - 5 times at intervals of approx. 5 minutes. When the platform reaches the bottom position - press and hold the DOWN button for about 15 seconds.
Lift does not lower	Incorrect electrical connection	Check the connections
	STOP button pressed in	Turn the button clockwise, raise the table a little to reset the downward travel.
	Power failure	Press the up button to reset the downward travel after a power failure.
	Safety frame activated	Switches cannot be activated. Align and adjust. Pressure the UP button briefly, and then DOWN button again.
	Lowering valve does not open	Check the power supply (DC). Replace the lowering valve if necessary.
	Supply voltage and fuses	Replace any blown fuses
The lift drops without the DOWN button being pressed	Dirt in the hydraulic system	Clean or replace the lowering valve
	Oil leakage	1) Check and repair hoses and hydraulic couplings. 2) Check the hydraulic cylinder's seals. Replace the seals if necessary.
	Oil leakage from the breathing hole in the top part of the cylinder	Leaking seals. Replace the seals.
Lowering speed higher or lower than desired	Incorrectly adjusted flow control valve	Adjust the flow control valve. NOTE! High speed means an increased risk of unstable goods.

# Manual Scissor Lift Table

## Oil Recommendations

Standard oils

Statoil	Hydraway HMA 46 (this oil is a part of the standard delivery)
Mobil	Mobil DTE 13
Castrol	Hyspin AWH

Product description with data and environment facts can be ordered from the manufacturer.

---

## Loading and Unloading

Loading and unloading on raised table should be don on the fixed side.

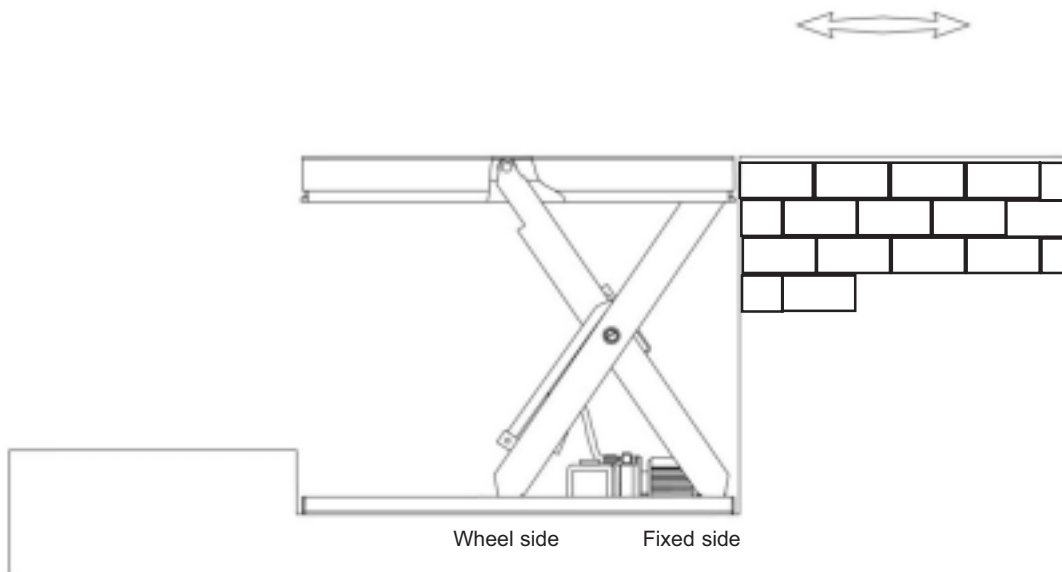

---

## Enclosed Appendices

- Machine Card
- Declaration of conformity (in some cases Manufacturer's declaration)
- Spare parts list
- Wiring diagram (if not standard)
- Hydraulic diagram (if not standard)



# Manual Scissor Lift Table

## Hydraulic diagram (standard)

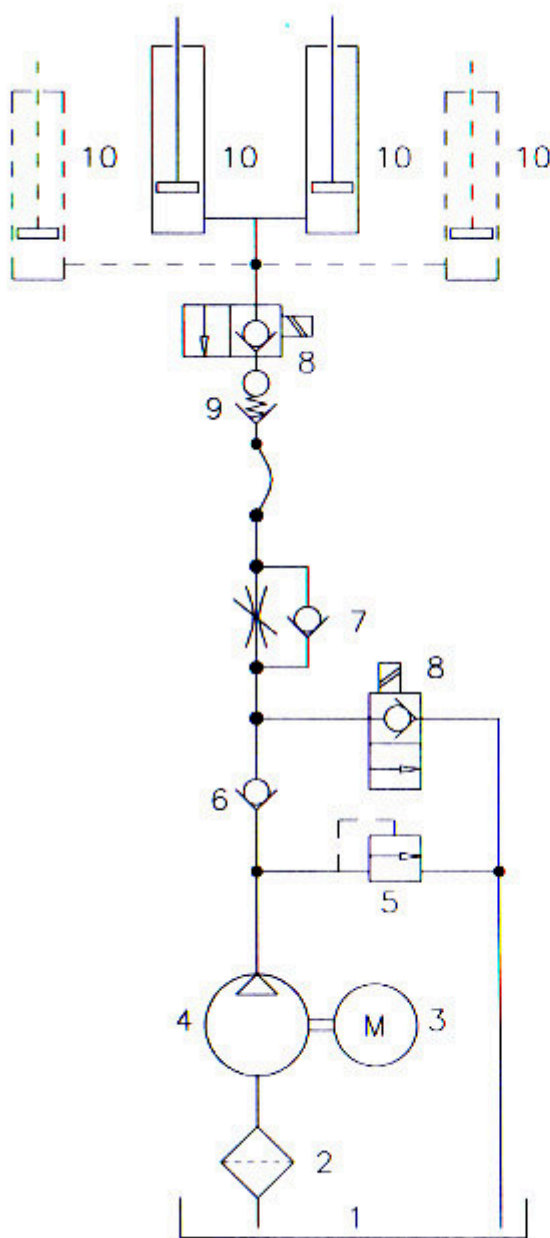

Diagram for lifting tables with two cylinders or more.

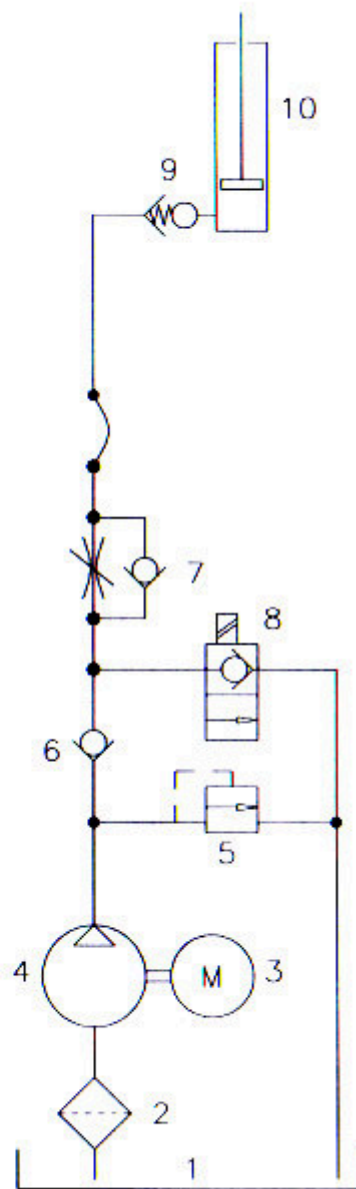

Diagram for lifting tables with only one cylinder.