



TEX16 Fully Powered Pallet Truck Stainless Steel With A.C.Technology

The TEX16 powered pallet truck is the ideal truck for use in the most inhospitable of environments.

- Capacity 1600 Kg.
- Manufactured from 100% 304 grade stainless steel, it is ideal for use in food, chemical and pharmaceuticals industries.
- The truck is protected to IP54 so can be hose washed.
- Uses latest AC control technology for superior control and battery life.
- Standard fork size for Euro pallet, other fork sizes available on request.
- Compact design allows for easy manoeuvring in narrow aisles.
- External battery charger.
- Ergonomic drive controls with microprocessor control.
- Includes stainless steel drive motor and gearbox.
- Heavy duty battery for a full day's continuous work.
- Smooth stepless drive controls.
- Trucks carry CE mark and comply with all current safety legislation.



Uses latest AC control technology for superior control and battery life

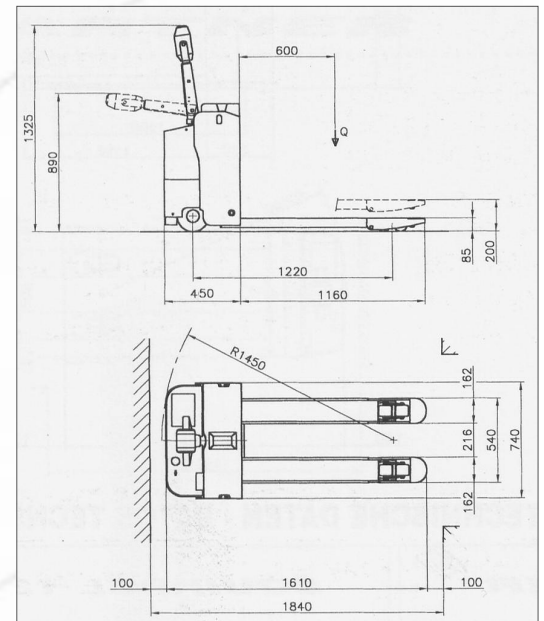

Model		TEX16
Capacity	Kg	1600
At Load Centre	mm	600
Fork Length	mm	1170
Fork Spread	mm	540
Overall Length	mm	1610
Overall Width	mm	740
Maximum Gradient Laden / Unladen	%	10 / 15
Wheels	Load Roller	mm Ø 80 x 70 Polyurethane Tandem
	Rear Wheels	mm Ø 100 x 35 Polyurethane
	Drive Wheel	mm Ø 250 x 80 Polyurethane
Brake		Electromagnetic
Battery	V / Ah	24 / 156
Charger	V / A	24 / 30
Truck Weight Inc. Battery	Kg	385



The TEX16 can also be fitted with an accurate built-in weighing system with fully functioned digital display. The weighing system is rated to IP65.